

Disassembly Drawing

B6250



Revision 1

1. Parts List

1.1 Caution for use of parts list

- ◆ The figures indicating the illustrations are the item No. in the list and present correspondence between the illustrations and parts.
- ◆ The notation of PL "X.Y.Z" is composed of the plate (PL), item "X.Y", and parts "Z".
- ◆ The alphabet characters in the illustrations represent screws and clips as follows:
"S": screw, "E": E-ring, "KL": KL clip, "C": C-ring, and "N": nut
- ◆ "t" mark in the illustrations are attached to items indicating assembly parts in the illustrations.
- ◆ Encircled alphabetical figures in the illustrations indicate interrupted leader lines. Same characters in the illustrations represent lines to be connected.
- ◆ The mark "(with 2-5)" attached to assembly parts on the illustrations and lists represents that the items "2, 3, 4, and 5" of that plate are contained and the mark "(with 2-5, PL6.1.1.1)" represent that the item "2, 3, 4, and 5" of that plate and the item "1" of the plate "6.1" are contained.
- ◆ The mark "[Same PLX.Y.Z]" attached to parts in the illustrations and lists represents that the parts is the same as the parts of the item "Z" of the plate "X.Y".
- ◆ The mark "H" attached to the item in the list represents "recommended spare parts" which can be usually supplied. (Supply of other parts shall be examined separately.)
- ◆ The mark "[" attached to parts in the list represents "Note" or "Reference" about that parts is contained in the same page.
- ◆ "HIGH ASSY" in the list represent the high level assembly parts containing that parts.

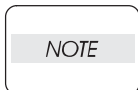

For spare parts, refer to the Spare parts list which is issued separately.

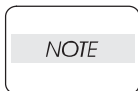

For the connector (P/J), parts such as harness, wire, etc. in the list, refer to Chapter 6, Electric wiring

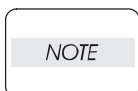

It should be noted that configuration of parts may be different or some parts are not used depending on specifications of OEM.

PL1.1 Cover [Illustration]

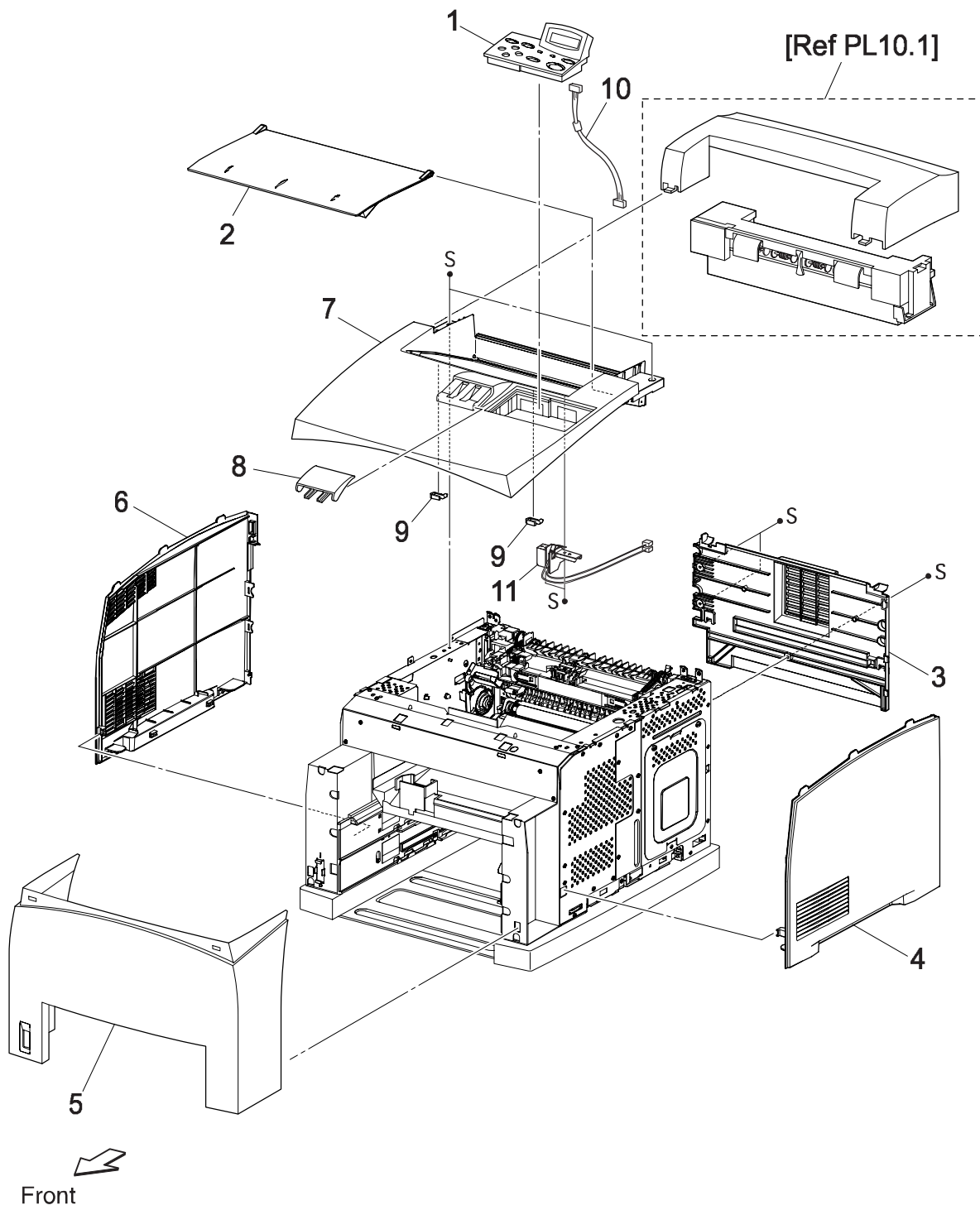

PL1.1 Cover [List]

Item	Parts name
1	OPERATION PANEL (P1)
2	COVER OPEN
3	COVER REAR
4	COVER RIGHT
5	COVER FRONT
6	COVER LEFT
7	COVER TOP
8	COVER STOPPER
9	STOPPER OPEN
10	HARNESS ASSY PANEL
11	SWITCH I/L ASSY (J144,J411)
12	--

PL2.1 150 Paper Cassette [Illustration]

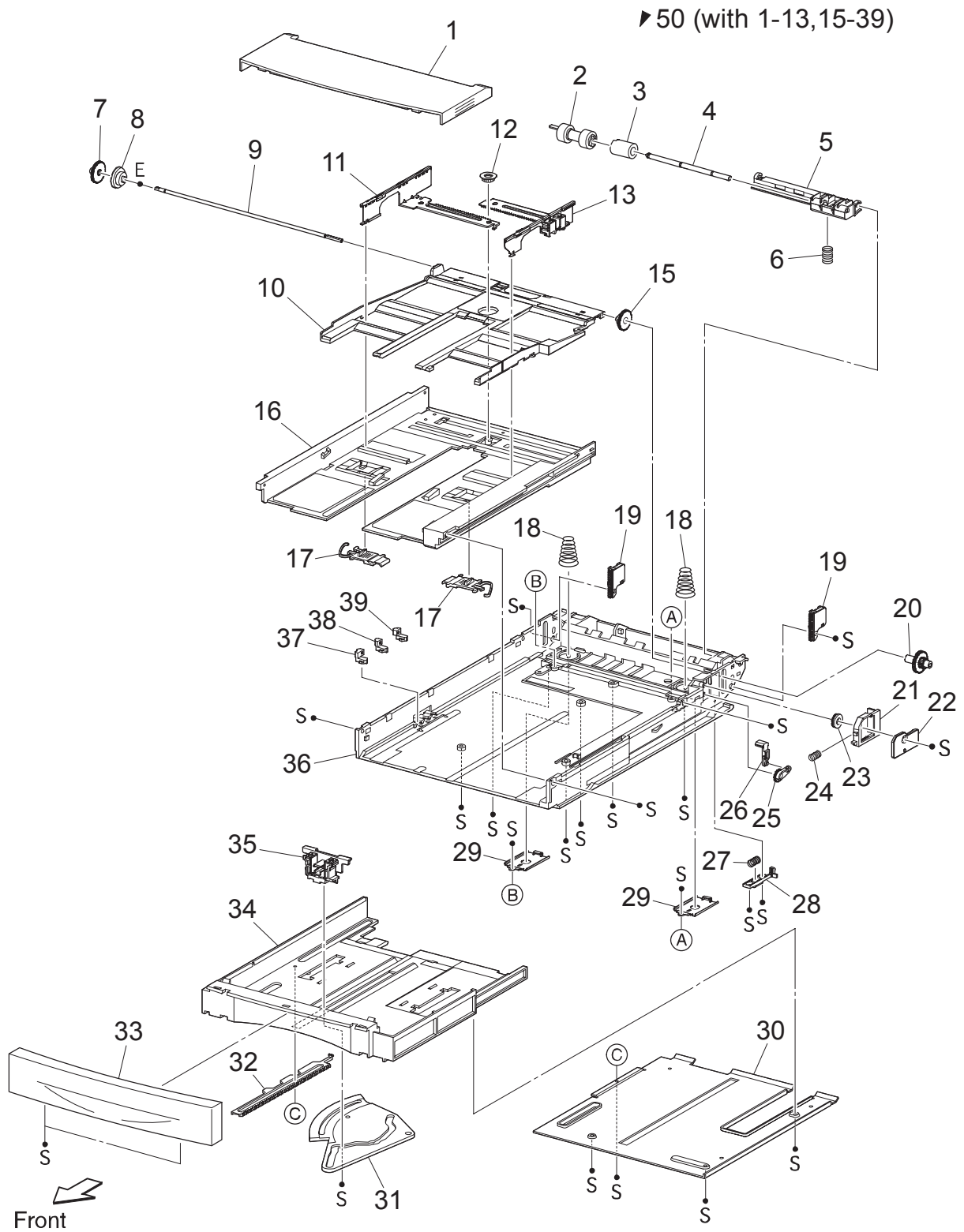

PL2.1 150 Paper Cassette [List]

Item	Parts name
1	COVER CST
2	ROLL ASSY RETARD *1
3	FRICITION CLUTCH
4	SHAFT RETARD
5	HOLDER RETARD
6	SPRING RETARD
7	GEAR PB L
8	GEAR BTM DMP ONEWAY
9	SHAFT PB
10	PLATE ASSY BTM
11	GUIDE ASSY SD L150
12	GEAR PINION
13	GUIDE ASSY SD R150
14	--
15	GEAR BTM LOCK ONEWAY
16	HOUSING TOP 150
17	LOCK EXTENSION
18	SPRING BTM UP 150
19	PLATE GEAR LOCK 150
20	GEAR PB R
21	RACK BTM LOCK 150
22	COVER BTM UP
23	GEAR BTM LOCK PINION
24	SPRING BTM LOCK
25	GEAR LEVER LOCK
26	LEVER BTM LOCK
27	SPRING STOPPER GEAR
28	STOPPER GEAR
29	PLATE SUPPORT BASE
30	COVER EXTENSION
31	GEAR SECTOR
32	RACK SIZE
33	HANDLE EXTENSION 150
34	HOUSING EXTENSION 150
35	GUIDE ASSY END 150
36	HOUSING BASE 150
37	LINK SW SIZE1-150
38	LINK SW SIZE2-150
39	LINK SW SIZE3-150
40	--
41	--
42	--
50	150 PAPER CASSETTE (with 1-13,15-39)
51	--

*1: Periodical Replacement parts (per 200k print)
3 sets [1] of PL2.1.2, PL5.1.11, 44

PL4.1 550 Paper Cassette [Illustration]

▼ 50 (with 1-13,15-32,34-48,52,53)

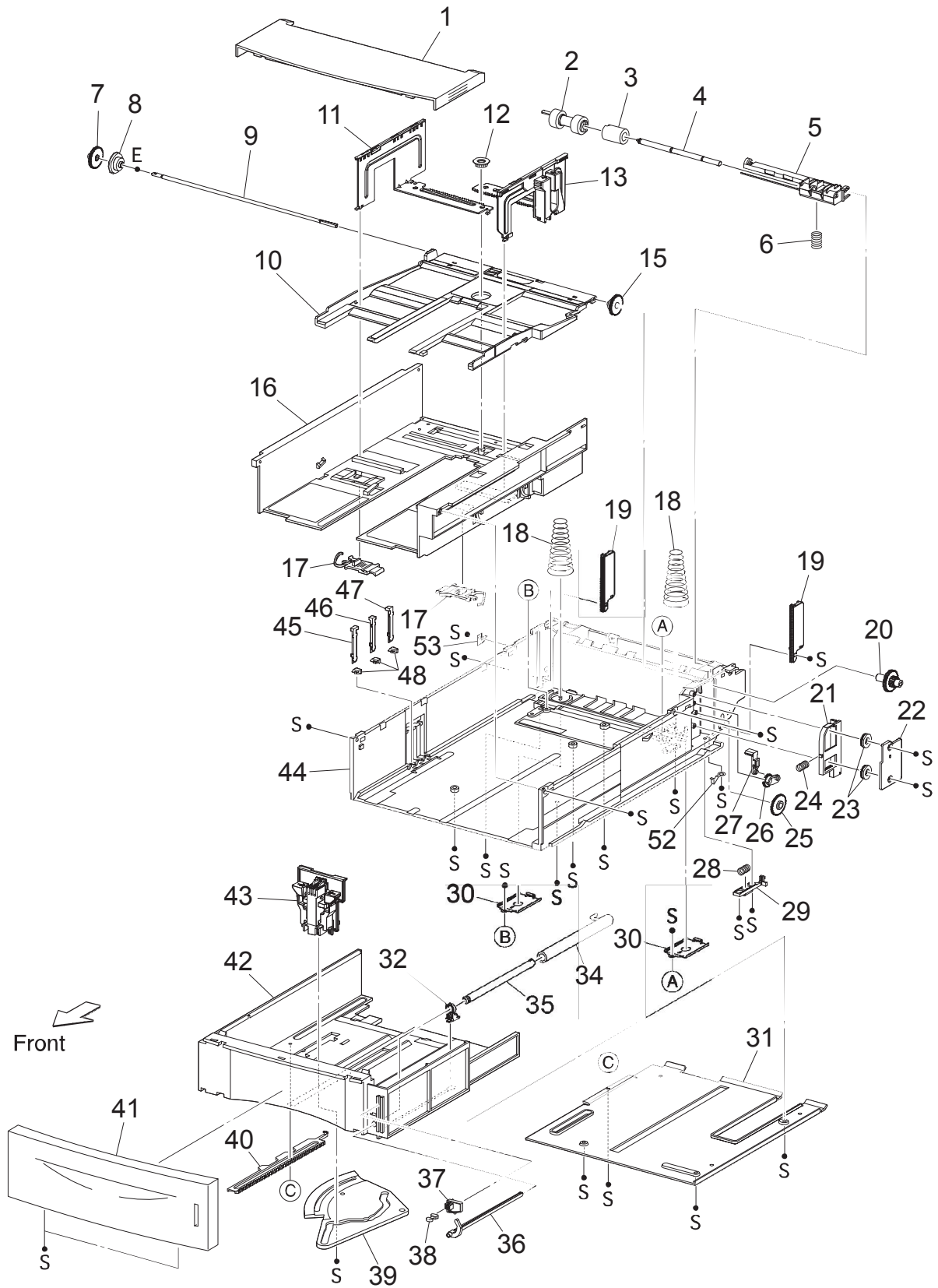

PL4.1 550 Paper Cassette [List]

Item	Parts name
1	COVER CST
2	ROLL ASSY RETARD *1
3	FRICTION CLUTCH
4	SHAFT RETARD
5	HOLDER RETARD
6	SPRING RETARD
7	GEAR PB L
8	GEAR BTM DMP ONEWAY
9	SHAFT PB
10	PLATE ASSY BTM
11	GUIDE ASSY SD L550
12	GEAR PINION
13	GUIDE ASSY SD R550
14	--
15	GEAR BTM LOCK ONEWAY
16	HOUSING TOP 550
17	LOCK EXTENSION
18	SPRING BTM UP 550
19	PLATE GEAR LOCK 550
20	GEAR PB R
21	RACK BTM LOCK 550
22	COVER BTM UP 550
23	GEAR BTM LOCK PINION
24	SPRING BTM LOCK
25	GEAR BTM LOCK
26	GEAR LEVER LOCK
27	LEVER BTM LOCK
28	SPRING STOPPER GEAR
29	STOPPER GEAR
30	PLATE SUPPORT
31	COVER EXTENSION
32	SUPPORT GUIDE IND
33	--
34	GUIDE INDICATOR 1
35	GUIDE INDICATOR 2
36	GUIDE INDICATOR 3
37	LOW INDICATOR
38	LOW IND FRONT
39	GEAR SECTOR
40	RACK SIZE
41	HANDLE EXTENSION 550
42	HOUSING EXTENSION 550
43	GUIDE ASSY END 550
44	HOUSING BASE 550
45	LINK SW SIZE1-550
46	LINK SW SIZE2-550
47	LINK SW SIZE3-550
48	LINK SW SIZE LOW
49	--
50	550 PAPER CASSETTE (with 1-13,15-32,34-48,52,53)
51	--
52	STOPPER BASE R
53	STOPPER BASE L

*1: Periodical Replacement parts (per 200k print)
3sets [1] of PL4.1.2, PL7.1.19, 29

PL5.1 150 Paper Feeder [Illustration]

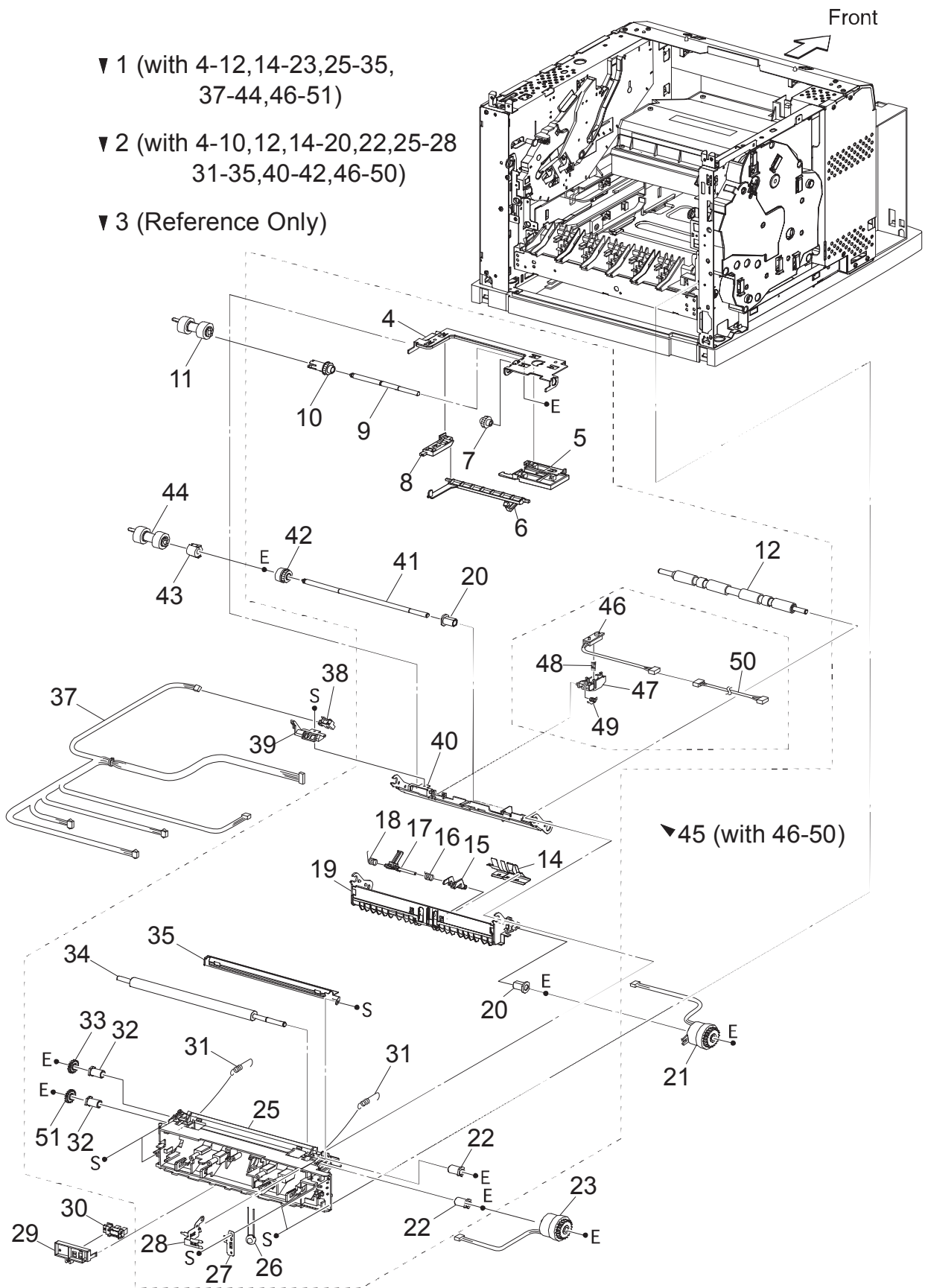

PL5.1 150 Paper Feeder [List]

Item	Parts name
1	150 FEEDER ASSY (with 4-12,14-23,25-35,37-44,46-51)
2	FDR1 AS SUB 150 A4 (with 4-10,12,14-20,22,25-28,31-35,40-42,46-50)
3	CHUTE ASSY FDR1 (Reference Only) (with 4-10,14-20,40-42)
4	SUPPORT NUDGER
5	HOLDER LEFT
6	ACTUATOR NO PAPER
7	GEAR IDLER NUDGER
8	HOLDER RIGHT
9	SHAFT NUDGER
10	GEAR NUDGER
11	ROLL ASSY NUDGER *1
12	ROLL REGI RUBBER
13	--
14	COVER ACTUATOR-A4
15	ACTUATOR A
16	SPRING REGI SNR B
17	ACTUATOR B
18	SPRING REGI SNR A
19	CHUTE BTM ASSY
20	BEARING NUDGER
21	CLUTCH ASSY PH (J242)
22	BEARING REGI LEFT
23	CLUTCH REGI (J243)
24	--
25	CHUTE REGI
26	VARISTER
27	EARTH PLATE BASE
28	EARTH PLATE MID
29	COVER SENSOR
30	SENSOR REGI (J241)
31	SPRING REGI
32	BEARING REGI RIGHT
33	GEAR REGI RUBBER BLUCK
34	ROLL REGI METAL
35	CHUTE EARTH REGI
36	--
37	HARNESS ASSY TRAY1 (J245-J240,J241,J242,J243,J244)
38	SENSOR NO PAPER (P240)
39	HOLDER NO PAPER SENSOR
40	CHUTE TOP ASSY
41	SHAFT FEED
42	CLUTCH ONEWAY NUDGER
43	CLUTCH ONEWAY FEED
44	ROLL ASSY FEED *1
45	SENSOR ASSY TONER (with 46-50)
46	SENSOR TONER (J220)
47	HOLDER-D
48	SPRING TONER
49	SPRING TONER BOX
50	HARNESS ASSY TONER 1 (J220-P221)
51	GEAR REGI METAL WHITE

*1: Periodical Replacement parts (per 200k print)
3sets [1] of PL5.1.11, 44, PL2.1.2

PL7.1 550 Paper Feeder [Illustration]

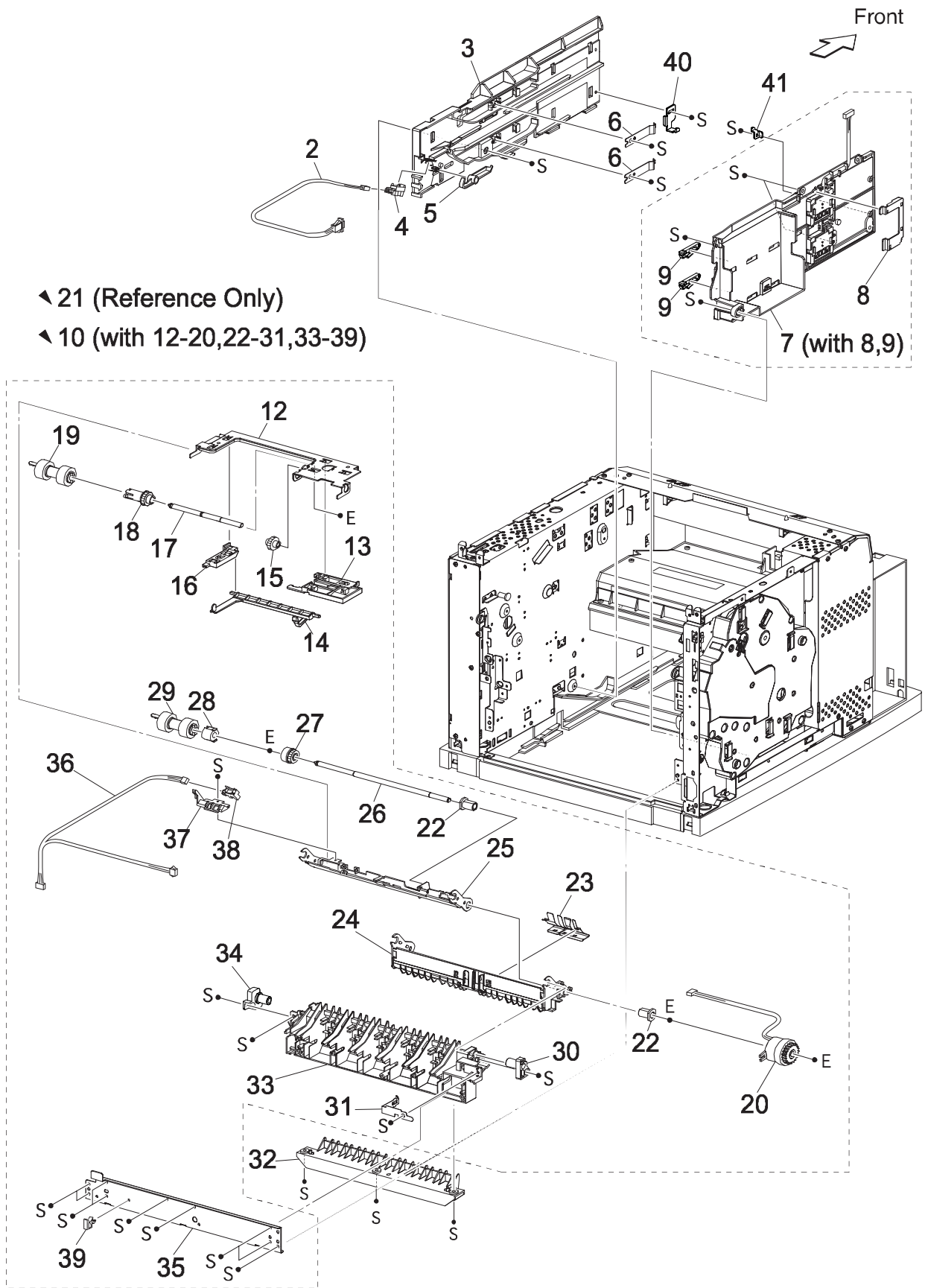

- ◀ 21 (Reference Only)
- ◀ 10 (with 12-20,22-31,33-39)

PL7.1 550 Paper Feeder [List]

Item	Parts name
1	--
2	HARNES ASSY LOW1 (J26-P260)
3	GUIDE TRAY RIGHT
4	SENSOR LOW PAPER (J260)
5	ACTUATOR LOW PAPER
6	PLATE CST LOCK
7	GUIDE TRAY LEFT (with 8,9)
8	COVER HARNES SIZE
9	LOCK CST L
10	550 FEEDER ASSY (with12-20,22-31,33-39)
11	--
12	SUPPORT NUDGER
13	HOLDER LEFT
14	ACTUATOR NO PAPER
15	GEAR IDLER NUDGER
16	HOLDER RIGHT
17	SHAFT NUDGER
18	GEAR NUDGER
19	ROLL ASSY NUDGER *1
20	CLUTCH ASSY PH (J247)
21	CHUTE ASSY FDR2 (Reference Only) (with 12-18,22-27)
22	BEARING NUDGER
23	COVER ACTUATOR
24	CHUTE BTM ASSY
25	CHUTE TOP ASSY
26	SHAFT FEED
27	CLUTCH ONEWAY NUDGER
28	CLUTCH ONEWAY FEED
29	ROLL ASSY FEED *1
30	HOLDER PIVOT LEFT
31	SPRING EARTH
32	CHUTE 550 LOWER
33	CHUTE OUT
34	HOLDER PIVOT RIGHT
35	PLATE TIE
36	HARNES ASSY TRAY2 (J248-J246,P247)
37	HOLDER NO PAPER SENSOR
38	SENSOR NO PAPER (P246)
39	CLAMP-10V0
40	STOPPER TRAY R
41	STOPPER TRAY L

*1: Periodical Replacement parts (per 200k print)
3sets [1] of PL7.1.19, 29, PL4.1.2

PL8.1 Xero [Illustration]

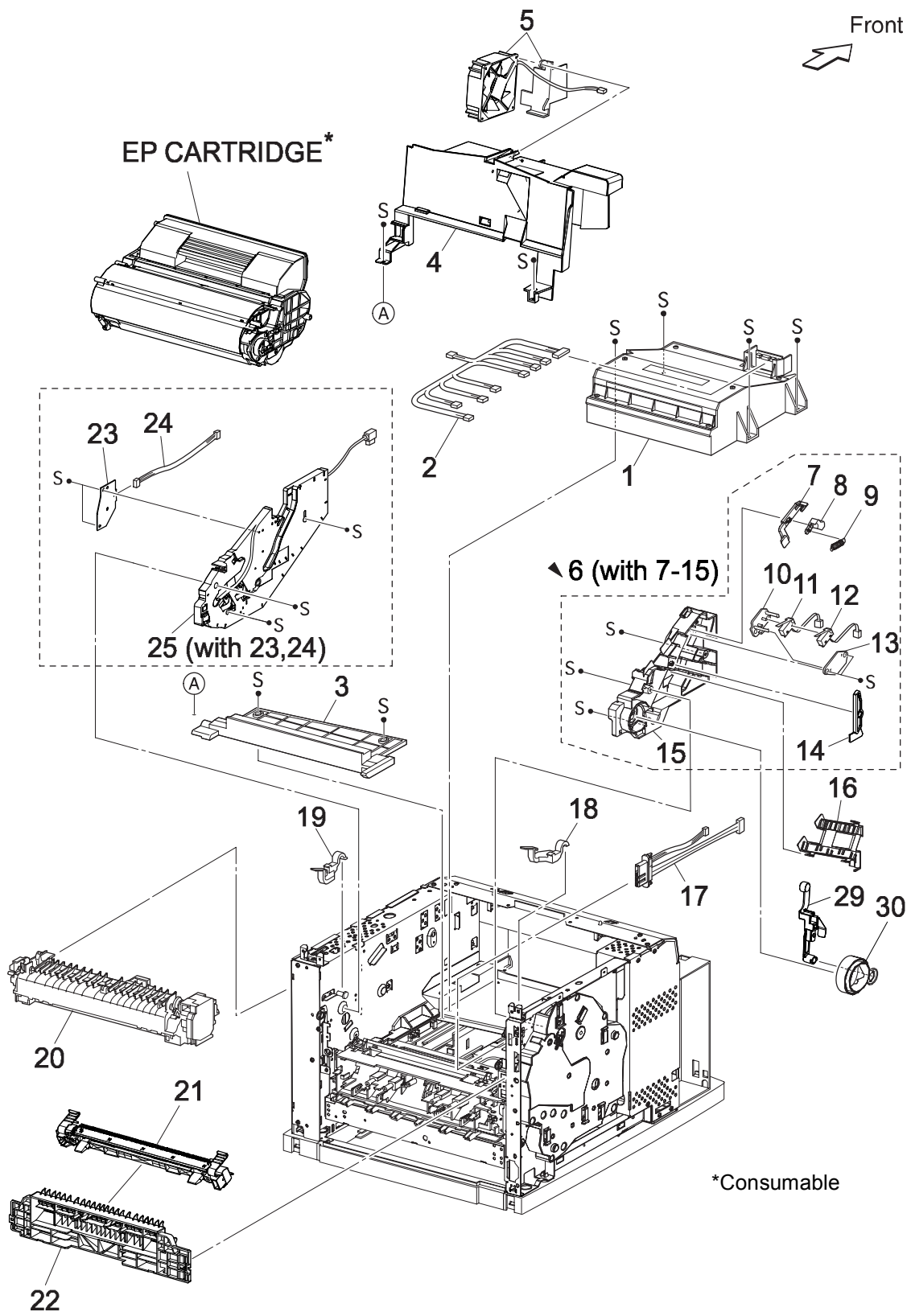

PL8.1 Xero [List]

Item	Parts name
1	ROS ASSY (J131,J140,J160,J170)
2	HARNESS ASSY ROS (J13,J14,J16,J17-P131,P140,P141,P160,P170)
3	SHIELD PLATE ROS
4	DUCT FRONT
5	FAN SUB (J270)
6	GUIDE ASSY CRU L (with 7-15)
7	GUIDE SL
8	SPACER SS
9	SPRING SL
10	HOLDER I/L SW1
11	INTERLOCK S/W 24V (J45)
12	INTERLOCK S/W 5V
13	HOLDER I/L SW2
14	LEVER GUIDE
15	GUIDE CRU LEFT
16	COVER GUIDE CRU
17	HARNESS ASSY FUSER (J4647-J46,J47)
18	LEVER FUSER LH
19	LEVER FUSER RH
20	FUSER ASSY *1
21	BTR ASSY *2
22	CHUTE TRANSFER
23	PWBA ASSY ANT (P150)
24	HARNESS ASSY ANT (J15-J150)
25	GUIDE ASSY CRU R (J31) (with 23,24)
26	--
27	--
28	--
29	LEVER LINK
30	LINK GEAR 3

*1: Periodical Replacement parts (per 200k print)

*2: Periodical Replacement parts (per 200k print)

PL10.1 500 Paper Exit (1/2) [List]

Item	Parts name
1	COVER EXIT 500
2	500 EXIT ASSY (with4-7,10-13,15-28,30)
3	--
4	CHUTE UP EXIT
5	ELIMINATOR EXIT
6	EARTH PLATE EXIT
7	LINK GATE OCT
8	--
9	--
10	ACTUATOR FULL STACK
11	BEARING EXIT
12	ROLL EXIT
13	GEAR 21
14	--
15	MOTOR ASSY EXIT (J103)
16	BRACKET MOTOR EXIT
17	GEAR 16/49
18	GEAR 25-2
19	GEAR 25-1
20	GATE OCT EXIT
21	CHUTE LOW EXIT
22	SPRING PINCH EXIT
23	ROLL PINCH EXIT
24	SPRING GATE OCT
25	SENSOR FACE UP OPEN (P291)
26	SENSOR FULL STACK (P290)
27	HARNESS ASSY EXIT SNR (J29-J290,J291)
28	ROLL EXIT 500
29	--
30	ROLL PINCH EXIT OCT

PL10.2 500 Paper Exit (2/2) & Option Face Up Tray [Illustration]

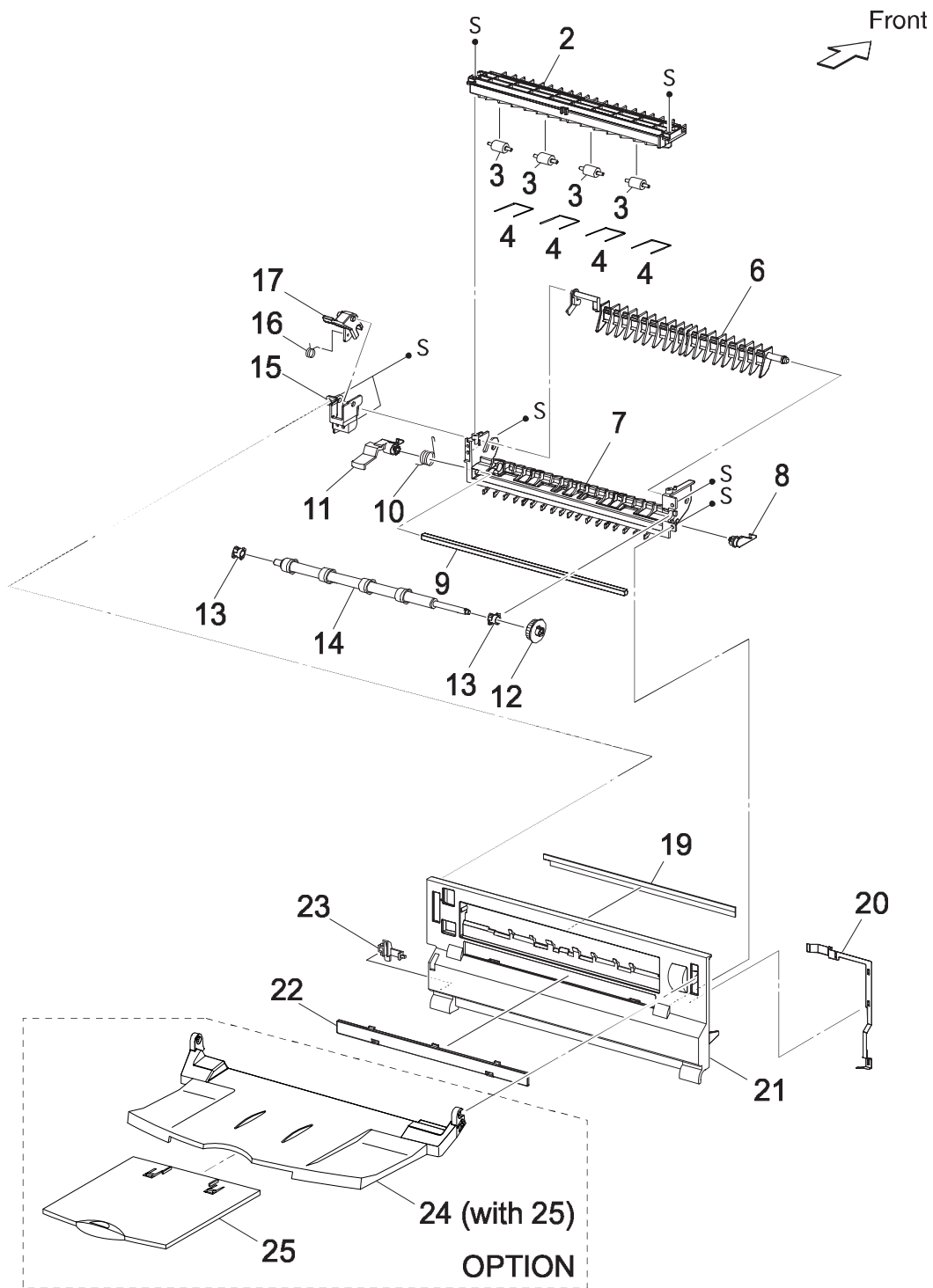

PL10.2 500 Paper Exit (2/2) & Option Face Up Tray [List]

Item	Parts name
1	--
2	CHUTE UP FU
3	ROLL PINCH FU
4	SPRING PINCH FU
5	--
6	GATE FU
7	CHUTE LOW FU
8	LEVER LATCH LEFT
9	PIPE LATCH FU
10	SPRING LATCH FU
11	LEVER LATCH RIGHT
12	GEAR 21
13	BEARING EXIT
14	ROLL FU
15	LEVER GATE HOLDER
16	SPRING LEVER GATE
17	LEVER GATE FU
18	--
19	ELIMINATOR EXIT FU
20	EARTH PLATE FU
21	COVER REAR 500
22	COVER DUP
23	STOPPER FSR
*24	TRAY FU A4 ASSY (with 25)
*25	TRAY FU SUB A4

*OPTION

PL11.1 Frame & Drive [Illustration]

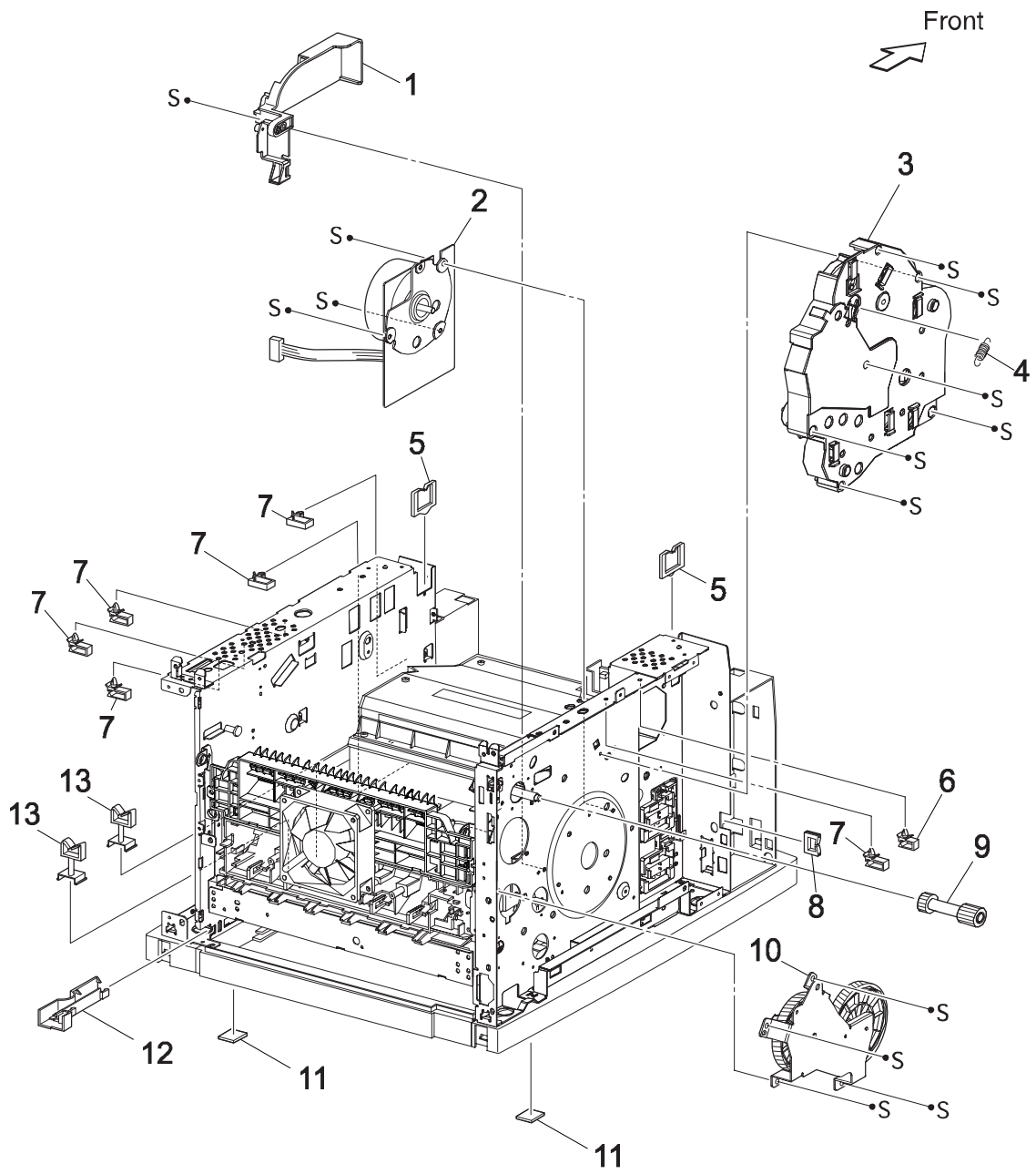

PL11.1 Frame & Drive [List]

Item	Parts name
1	MOTOR COVER
2	MAIN MOTOR (J43)
3	GEAR ASSY HOUSING
4	SPRING RELEASE
5	CLAMP-EDGE
6	CLAMP-5V0
7	CLAMP-10V0
8	CLAMP-EDGE
9	GEAR 9
10	GEAR ASSY PLATE
11	FOOT
12	GUIDE HARNESS R
13	CLAMP-RWSH
14	--
15	--
16	--

PL12.1 Electrical [Illustration]

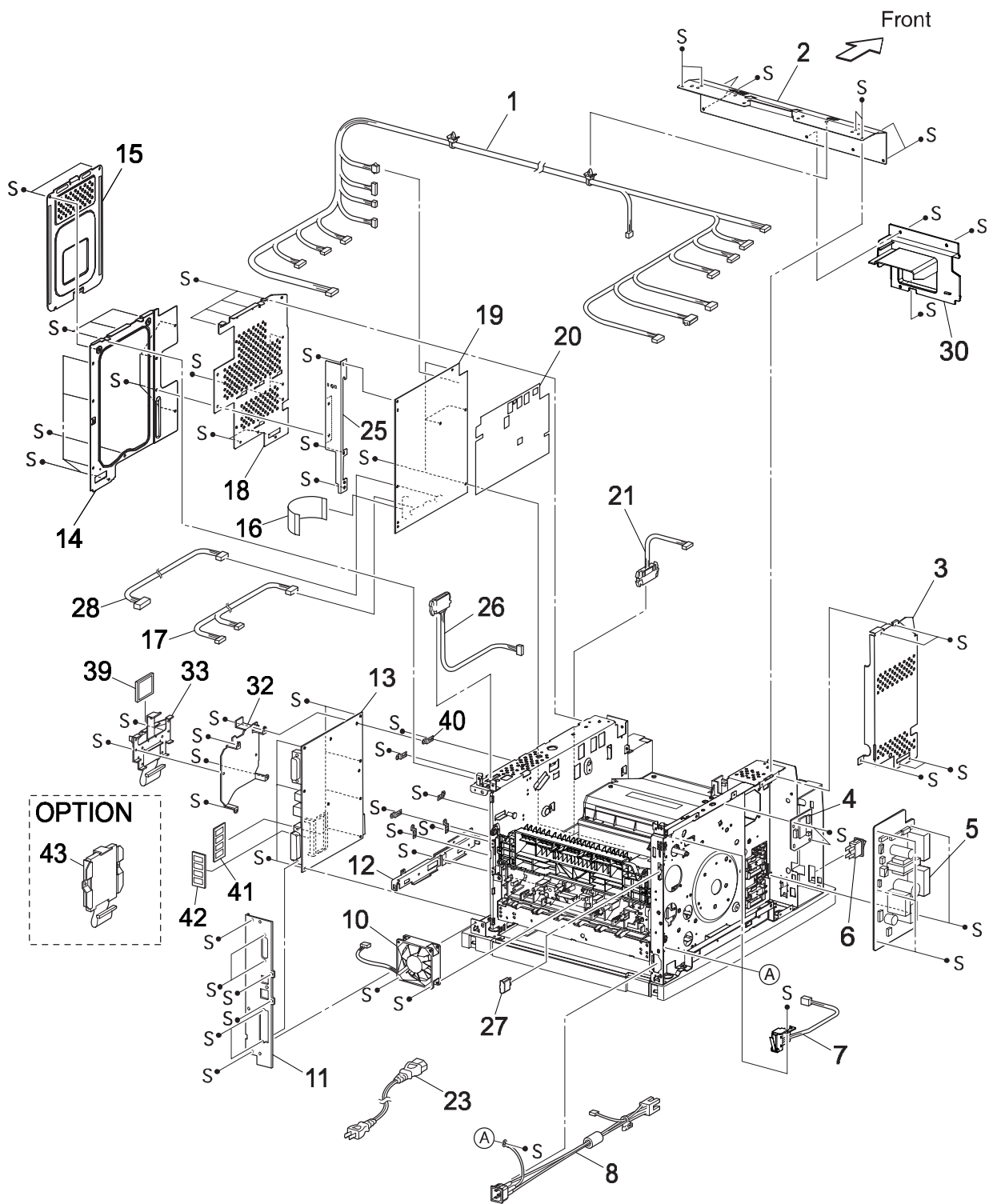

PL12.1 Electrical [List]

Item	Parts name
1	HARNESS ASSY LVPS (J10,J11,J18,J27,CNPOW,J141-J42,J41,J1821,P270,J102,P2750,J40,P142,P144,J411,J400)
2	PLATE TIE FRONT
3	SHIELD PLATE LVPS
4	PWBA EXIT MOTOR
5	LVPS
6	POWER SWITCH
7	INTERLOCK S/W REAR (J44)
8	HARNESS ASSY AC100V/AC200V (J48,J480)
9	--
10	FAN MAIN (J244)
11	PANEL REAR
12	BRACKET HANDLE R
13	PWBA ESS
14	SHIELD ASSY ESS
15	SHIELD ASSY WINDOW
16	FFC ASSY ESS (P28-CNVD)
17	HARNESS ASSY CHUTE (J24-P245,P248)
18	SHIELD PLATE HVPS
19	HVPS/MCU
20	MAYLER HVPS
21	HARNESS ASSY FDR1 (J20-P2083)
22	--
23	POWER CORD
24	--
25	BRACKET SHIELD HVPS
26	HARNESS ASSY OCT 1 (J30-P3070)
27	CAP CONNECTOR-DRAWER
28	HARNESS ASSY TONER 2 (J22-P221)
29	--
30	DUCT HIGH
31	--
32	BRACKET-PWBA HDD
33	BRACKET ASSY-FLASH
34	--
35	--
36	--
37	--
38	--
39	CF CARD
40	BRACKET BOARD
41	MEMORY OPTION
42	NET OPTION
43	HDD ASSY (OPTION)